

class *range*

classical machines for the advanced joinery

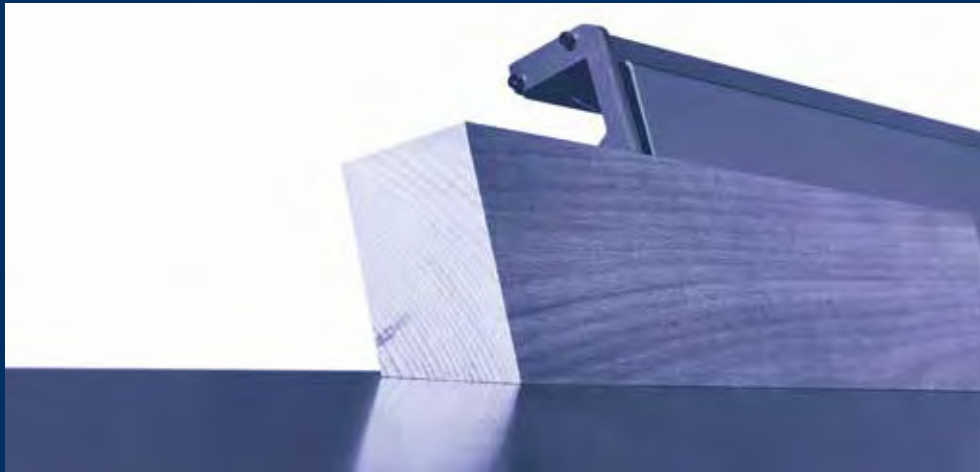

All “Made in SCM Italy”

From casting iron to finished product.

Come see our production plants and touch the quality of SCM machines;
you will be our guest.



Classical machines for the advanced joinery.

SCM's objective is to guarantee customers high quality technologies which meet their requirements in such a way as to make SCM the partner for any needs.

class *range*

The best solution for every application.

circular saws	programmable
	manual

class si x
page 6



class si 550ep
page 7



class si 400ep
page 7



class px 350i
page 22



class si 400
page 8



class si 350
page 9



class si 300
page 9



automatic multiblade rip saw

class m 3
page 26



class f 520
page 30



class f 410
page 30



planers	surface planers
	thickening planers

class s 630
page 31



class s 520
page 31



spindle moulders	electronically and programmable
	manual

class ti 145ep
page 38



class ti 120e
page 39



class ti 130e
page 39



class tf 130
page 40



class tf 130ps
page 41



class ti 120
page 41





APP Thundercut

Technology at your fingertips

SCM Thundercut is the Optimizer/Sequencer App for mobile devices that allows to optimize the panel surface and guides the operator through the cutting sequence.

High cut speed execution, less material waste and mistake odds minimized, even for not skilled workers!

Download it now from the AppStore and Google Play:

SCM Thundercut

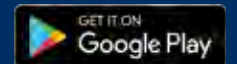

You can manage your circular saws fleet, the material warehouse and many project you are working on.



The 3D sequencer, thanks to its simple and clear design, suggest the ideal settings of the machine for every single cut to be executed.

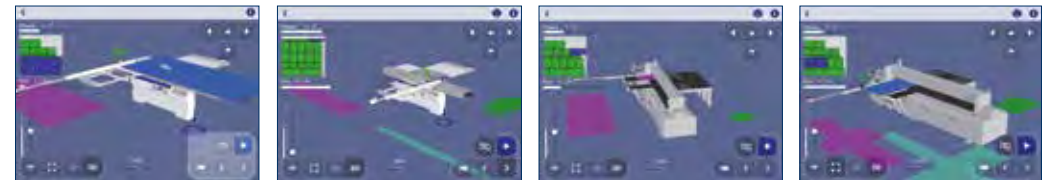

The App is available for circular saws, circular saws with movable blade unit, saw-shaper combination machines and universal combination machines (you will find the QR code to activate the App in each new machine).



SCM CLASSICAL MACHINES, QUALITY EVEN MORE GUARANTEED

Since 1952, SCM has been leader in the design and production of woodworking machines.

We are getting closer to reach 70 years of company history by offering to our customers knowledge and advanced technologies that distinguish **L'invincibile, class** and **nova** classical machines. Different ranges united by the strength points: performance, ease-of-use and certified quality. We believe so much in the reliability of our machines to offer to our customers the possibility to have a **warranty extended up to 2 years***. An extra peace of mind for small artisans workshops and joineries who see SCM as the ideal partner to grow their business.

To activate the 2-year warranty extension, it is compulsory to register on-line the machine on the website:

scmwood.com/warranty-extension

*Check the models of machines that can take advantage of the initiative on the website:

scmwood.com/joinery-machines





programmable
circular saws
class si x
class si 550ep
class si 400ep



±46° double tilting blade.

		class si x	class si 550ep	class si 400ep
Max. saw blade diameter	mm	550	550*	400
Max. saw blade diameter with installed scoring unit	mm	450**	-	400
Max. saw blade projection from the table at 90°/+45°/-45°	mm	200/130/105	200/130/-	140/97/-
Saw blade rotating speed	rpm	3000 ÷ 5000	2500/3500/5000	3000/4000/5000
Squaring stroke	mm	2200 ÷ 3800	2200 ÷ 3800	2200 ÷ 3800
Cutting width on rip fence	mm	1000 ÷ 1500	1000 ÷ 1500	1000 ÷ 1500
Three-phase motors power starting from	kW/Hz	9 (11) / 50 (60)	7 (8) / 50 (60)	7 (8) / 50 (60)

Find the complete technical specification at page 20

* The machine is not equipped with scoring unit

** Scoring unit as option



Saw Unit
sturdy structure

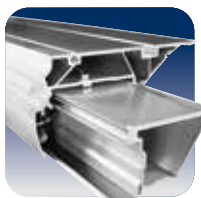

Sliding Carriage
high cutting quality



Rip Fence
smoothness and precision



Electronic Control
precision and ease-of-use



SCM
Thundercut
Optimizer/
Sequencer App

Superior technology combined with an ease-of-use.



manual
circular saws
class si 400
class si 350
class si 300



		class si 400	class si 350	class si 300
Max. saw blade diameter with installed scoring unit	mm	400	350	315
Max. saw blade projection from the table at 90°/45°	mm	140/97	118/81	100/70
Saw blade rotating speed	rpm	3000/4000/5000	4000	4000
Squaring stroke	mm	2200 ÷ 3800	2200 ÷ 3800	2200 ÷ 3800
Cutting width on rip fence	mm	1000 ÷ 1500	1000 ÷ 1500	1000 ÷ 1500
Three-phase motors power starting from	kW/Hz	7 (8) / 50 (60)	7 (8) / 50 (60)	5 (6) / 50 (60)

Find the complete technical specification at page 20



Saw Unit
sturdy structure

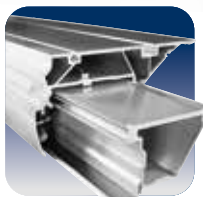

Sliding Carriage
high cutting quality



Rip Fence
smoothness and precision



SCM
Thundercut
Optimizer/
Sequencer App

High construction quality for reliability and safe performance.

circular saws operating groups

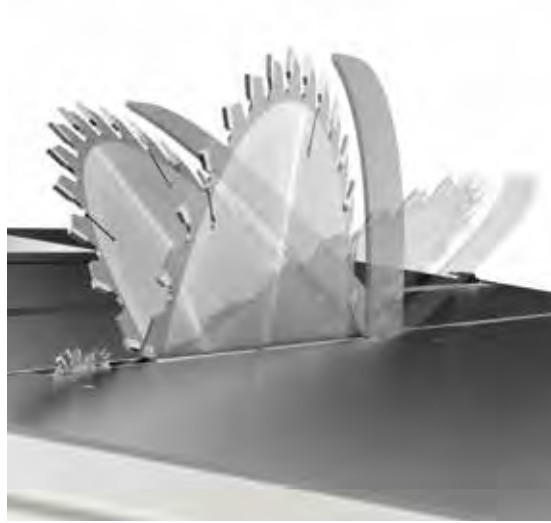

always user friendly
and precise

Handwheels on the machine front

Ease-of-use in every day operation due to the dedicated gear box (**SCM solution**), fully protected from dust, that provides a smooth and direct transmission. Every minimum hand-wheel movement corresponds to a precise blade adjustment.

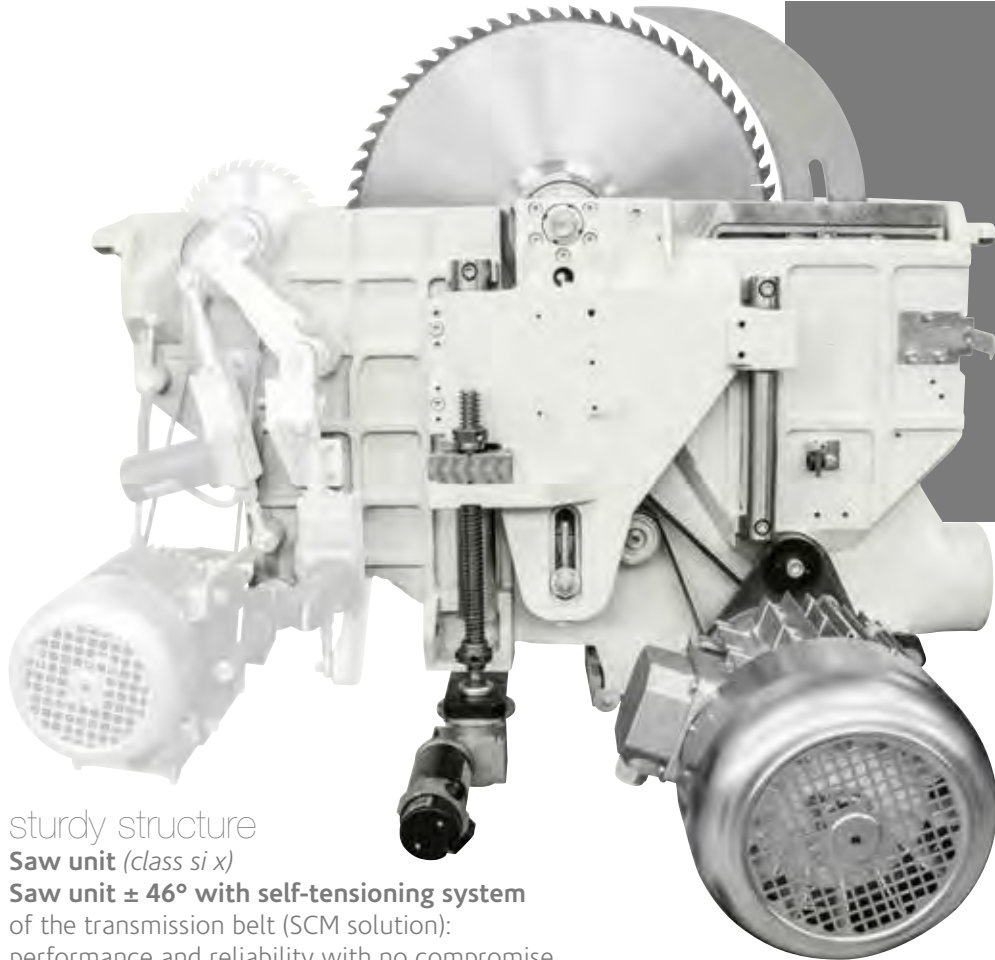

sturdy structure

Saw unit (class si x)

Saw unit $\pm 46^\circ$ with self-tensioning system of the transmission belt (SCM solution): performance and reliability with no compromise.

The saw blade lifting is carried out by a strong cast-iron structure with sliding on ground round slideways which guarantee the **best accuracy**. The unit tilting is carried out on cast-iron rotation sectors in a crescent shape to ensure reliability over time.



simple and effective

Scoring unit adjustment

Vertical and horizontal adjustments are carried out by user-friendly mechanical levers that operate directly making precise and smooth movements. The useful mechanical stops allow immediately finding of the set position. The positioning of the controls allows their use without moving from the front of the machine.



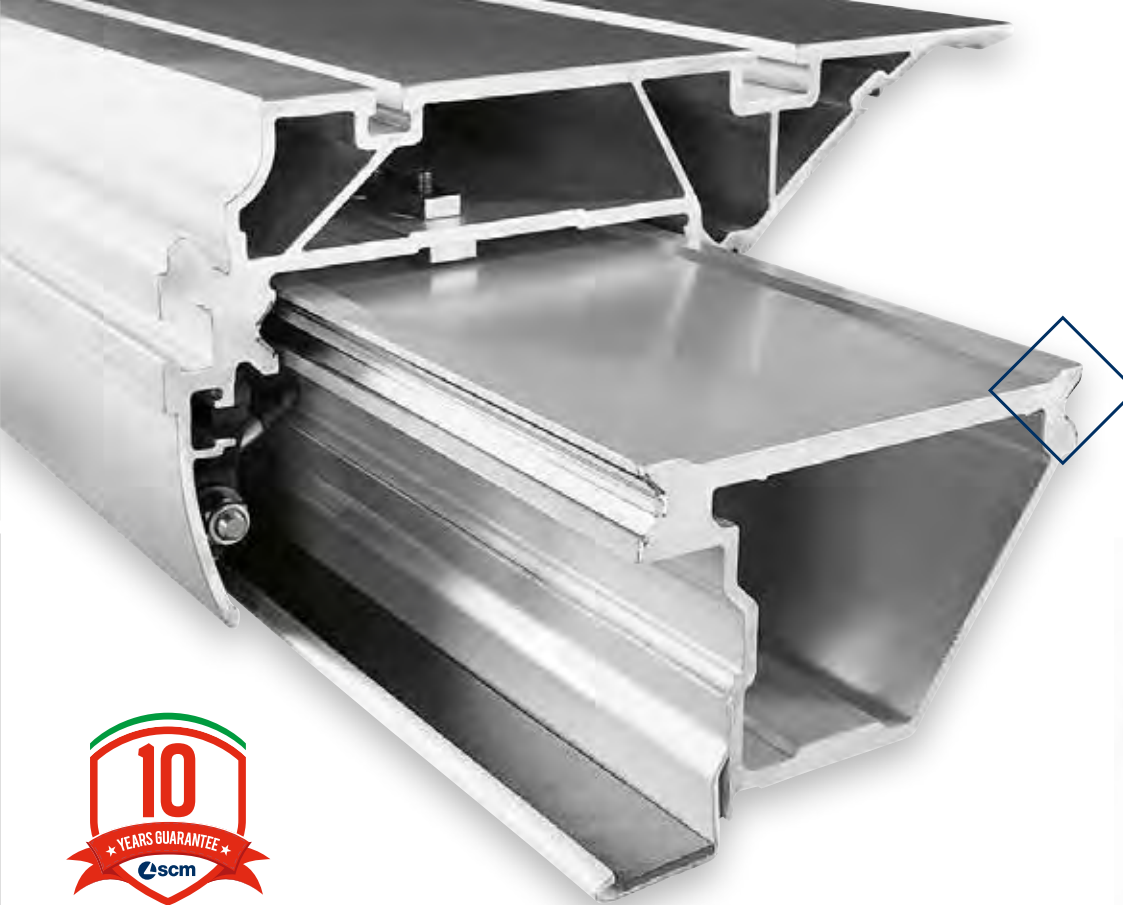

maximum cut quality guaranteed over time

Sliding carriage

The carriage will never require adjustment due to its closed reticular geometry with steel guides using an **exclusive method of mechanical fixing**.



Furthermore, the **"arc" profile of the class arch-ground steel slideways (SCM solution)** ensures:

- No play and loads four times higher than others
- +/-0,05 mm tolerance on the entire carriage length for straight and high quality cutting
- Sliding effectiveness over time, thanks to the particular guides positioning which ensures protection from dust



reliability and technology without comparison
10 years of SCM guarantee for the carriage sliding system.



optimal support

Squaring frame and fence

Panel loading is easy on the large squaring frame with an idle roller at the end and the mobile cross beams offer an **optimal support** also to smaller panels. The telescopic squaring fence with the inclined metric scale and two reversible stops can be used to square panels measuring 3200x3800 mm and for tilted cuts at up to 45° on both sides of the frame.

smooth, rapid and precise positioning

Rip fence

Sliding of the rip fence support on round bar with micrometric adjustment.

The support can be also equipped with digital readout for fence position with detecting system on magnetic band (option). The fence can be easily excluded from the working area when it isn't used.



programmable circular saws electronic controls

Technical specification at page 21



the practical advantage for automatic control of the main positions
"Ready"

The **programming** of the work becomes **simple and effective** with the electronic control with a 4" LCD display.

- Working mode: manual, semi-automatic and automatic with a memory capacity of up to 99 programs
- Tool data setting with automatic height adjustment
- Calculator and hour counter



Saw unit lifting Saw unit tilting Programmable rip fence (option) Blade speed readout

the pleasure of controlling all machine functions from the control panel
"eye-S" console

The new control panel, with its attractive design, allows easy and intuitive machine programming, combining the 15" colour touch-screen display and the **Maestro** active user interface. Main functions:

- Connectivity among machines belonging to the same company network and **4.0 Industry** preset
- Sharing of work programs and tools database
- Activity monitoring and reporting on the use of the machine
- Connectivity with **SCM Thundercut** (optimizer/sequencer App)
- Self-diagnosis, tele-service and link to troubleshooting



one cut only, the correct one
Operator's support

The large display suggests to the operator information for the correct use of any cutting configuration. In particular, it displays in real time the correct position of the stop on the basis of the known measurements of the work-piece (**SCM solution**).



The **"eye-S"** control can manage the inverter for the adjustment of the saw blade rotation speed and the scoring unit alignment.





speed and accuracy

Motorised programmable rip fence mounted on a recirculating ball screw mechanism with sliding on linear guides.
Only for Ready 3 Plus / eye-S



maximum practicality

Pushbuttons integrated in the sliding carriage

The possibility to start or stop the blades motors from the pushbuttons located at the ends of the carriage **considerably helps when machining large dimensioned panels.**
(option)

the innovation at the operator service
Automatic positioning system of the overhead protection

The overhead protection automatically positions itself as a function of the blade using the **exclusive "AP system" (SCM solution).**
 This makes the transition from cuts with different angles even faster and safe, without the operator having to change the settings of the machine.
(class si x)



practicality and safety

Motorized programmable rip fence with steel cable and sliding on sturdy round steel bar.

Position readout on magnetic band.
Only for Ready 3 version



circular saws main optional devices

Angular cutting devices

Available for the following versions

- a) traditional
- b) with automatic self-adjustment of the stops position in respect of the blade
- c) with automatic self-adjustment of the stops position in respect of the blade and electronic readouts for stop position and rule tilting angle

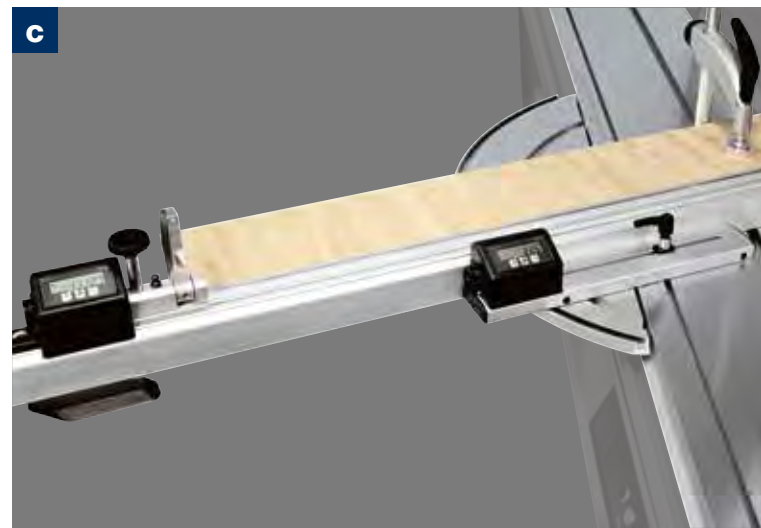
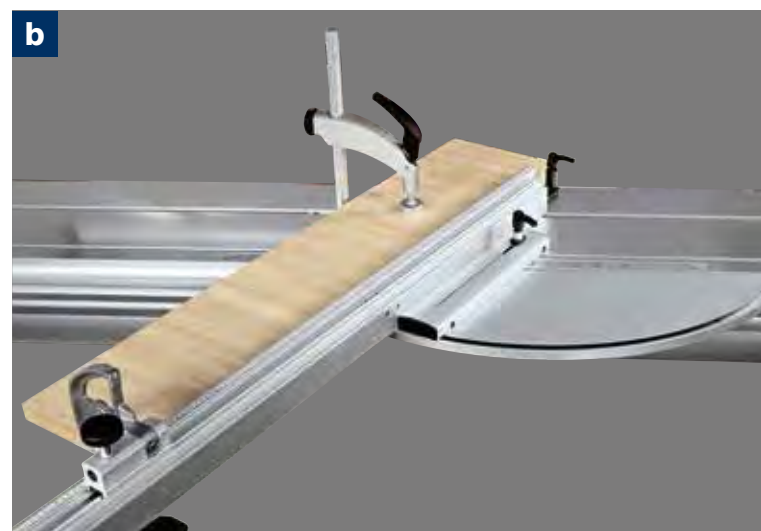

Rip fence unit

The exclusive referencing system for the first trim cut allows the setting of trim quantity to be cut for every **side without any test cuts**. Available also with electronic readouts.





Squaring frame with "Compex" device
 with automatic self-adjustment of stops position in respect of the blade and rule tilting angle. Furthermore, thanks to the dedicated frame structure, it is possible to carry out **tilted cuts keeping the squaring rule comfortably within the operator's reach**, both in acute cuts and in obtuse ones, without renouncing to a valid support of the piece.

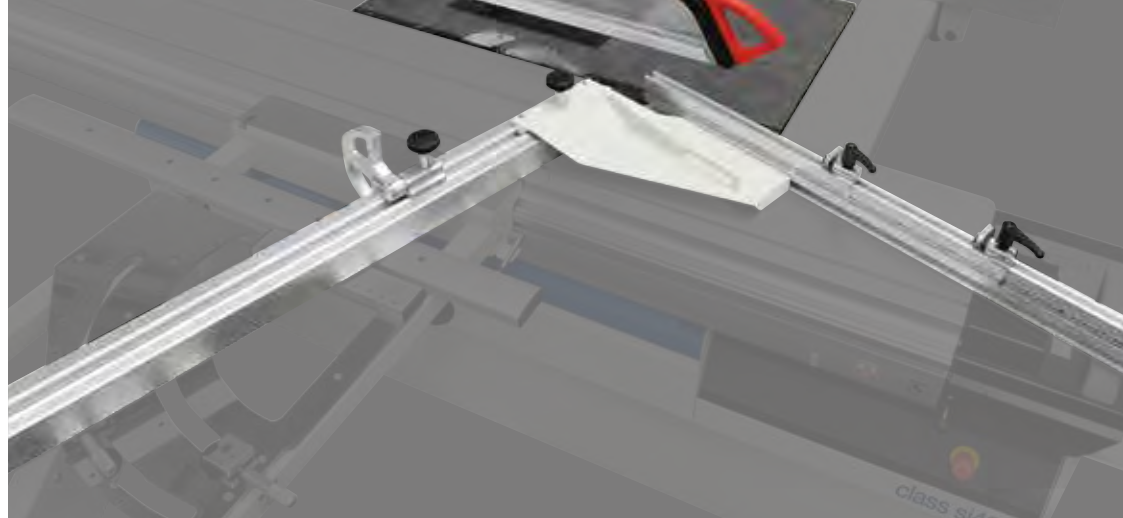

Fence for complementary cutting
 Device to be applied directly on the squaring rule that allows to quickly carry out cuts with angles complementary to the rule one.



Squaring stops with lens
 For a better view of the data.



Electronic readouts on the squaring stops
 The stops can be easily read even from distance.

speed and precision
"Quick Lock" squaring fence with rapid release
 Minimum set-up time with the **SCM system that allows rapid fence positioning**.
 The extending roller and the stronger frame support maximise performance.



circular saws main optional devices

Surface reinforcement treatment
For sliding table and mobile crossbars of squaring frame.
Dedicated to the intensive processing and particularly abrasive materials.

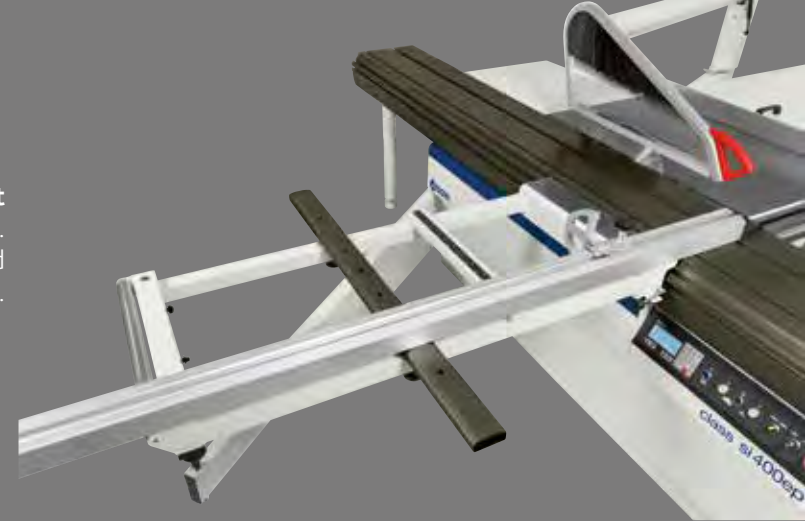

Extension with roller conveyor on parallel fence side,
for the support of large panels, and tools-holder to have the tools always within reach.



Laser device
Laser light for the work-piece alignment with the cutting line.



Mechanical preset for "DADO" machining
Possibility of using a tool (not included) to replace the main blade, with 203 mm maximum diameter and 20 mm maximum thickness.



circular
saws
main
optional
devices

Tablet holder on the sliding carriage
Compatible with tablets from 8" to 11".



Adjustable tablet holder positioned on the mobile control panel
Compatible with tablets from 7" to 13".
It is equipped with USB port for power supply positioned
on the mobile control panel.

circular saws main optional devices



"Pro-Lock"

System for the main blade rapid locking with fast and tool-less riving knife adjustment.

Expandable scoring blade

Manually expandable with variable thickness from 2,8 to 3,6 mm.
Blade diameter: 120 mm (160 mm for *class si x*)



Blades-holder drawer integrated in the machine's frame

It is made of 4 shelves, customizable with labels, for the easy replacement of the blades.

"LED indicating scoring unit in operation" device

When the scoring blade is working, the high efficiency LEDs clearly indicate the danger area, making the machine safer than ever.



Pneumatic presser

Particularly suitable for the cutting of thin materials.



Second extension with sliding rail support

to safely support panels for large dimension and weight.



Advanced materials machining

PVC and other plastic materials. Nylon, polycarbonate and other synthetic materials. Corian and other composite materials. Aluminium, brass and other light metals.

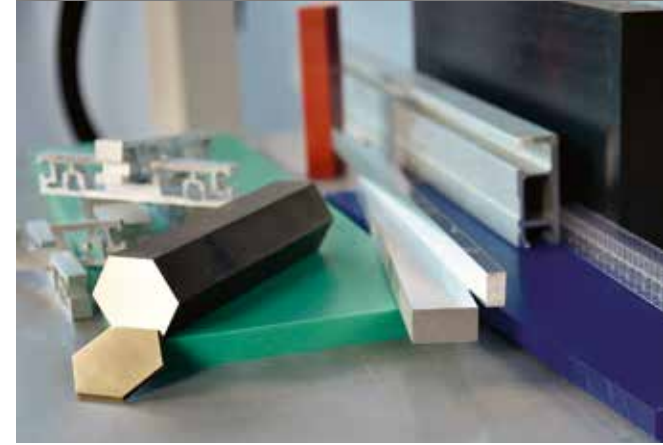

Device for the blade micro-lubrication

Compulsory for the machining of light alloys, extremely useful with particular plastic materials.



circular saws technical data

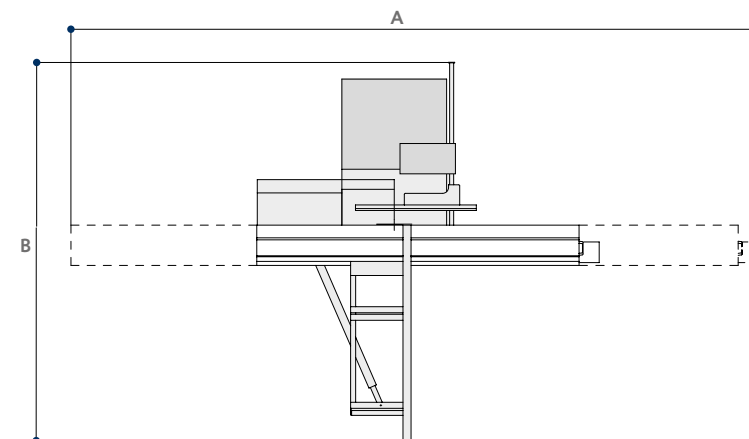
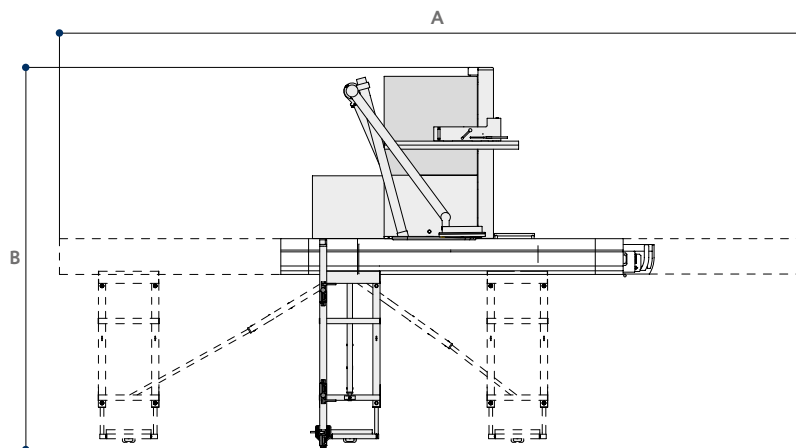

S Standard
O Option

TECHNICAL DATA		class si x	class si 550ep	class si 400ep	class si 400	class si 350	class si 300
Cast-iron saw table dimensions	mm	1285 x 700	1285 x 700	1040 x 630	1040 x 630	1040 x 630	900 x 550
Blades tilting	mm	-46° ÷ +46°	90° ÷ 45°	90° ÷ 45°	90° ÷ 45°	90° ÷ 45°	90° ÷ 45°
Max. saw blade diameter		550	550*	400	400	350	315
Max. saw blade diameter with installed scoring unit	mm	450**	-	400	400	350	315
Max. saw blade projection from the table at 90°/+45°/-45°	mm	200/130/105	200/130/-	140/97/-	140/97/-	118/81/-	100/70/-
Saw blade rotating speed	rpm	3000 ÷ 5000	2500/3500/5000	3000/4000/5000	3000/4000/5000	4000	4000
Squaring stroke	mm	2200 ÷ 3800	2200 ÷ 3800	2200 ÷ 3800	2200 ÷ 3800	2200 ÷ 3800	2200 ÷ 3800
Cutting width on rip fence	mm	1000 ÷ 1500	1000 ÷ 1500	1000 ÷ 1500	1000 ÷ 1500	1000 ÷ 1500	1000 ÷ 1500
other technical features							
Three-phase motors 5 kW (6,6 hp) 50 Hz - 6 kW (8 hp) 60 Hz		-	-	-	-	-	S
Three-phase motors 7 kW (9,5 hp) 50 Hz - 8 kW (11 hp) 60 Hz		-	S	S	S	S	O
Three-phase motors 9 kW (12 hp) 50 Hz - 11 kW (15 hp) 60 Hz		S	O	O	O	-	-
Three-phase motors 14 kW (19 hp) 50 Hz - 14 kW (19 hp) 60 Hz		-	O	-	-	-	-
Exhaus hoods diameter:							
- at the base	mm	120	120	120	120	120	120
- on overhead protection	mm	100	100	100	100	100	100
- on riving knife	mm	-	-	60	60	60	60

* The machine is not equipped with scoring unit

** Scoring unit as option

OVERALL DIMENSIONS		class si x	class si 550ep	class si 400ep	class si 400	class si 350	class si 300
A with 2200 mm carriage	mm	5230	5230	5230	5090	5090	5090
A with 3200 mm carriage	mm	7250	7250	7250	6825	6825	6825
A with 3800 mm carriage	mm	8500	8500	8500	7425	7425	7425
B with 1000 mm cutting width on rip fence	mm	4042	3922	3815	3740	3740	3597
B with 1270 mm cutting width on rip fence	mm	4367	4247	4140	4110	4110	3867
B with 1500 mm cutting width on rip fence	mm	4492	4372	4265	4235	4235	4097

MAIN OPTIONAL DEVICES		class si x	class si 550ep	class si 400ep	class si 400	class si 350	class si 300
"Ready 3" version		-	0	0	-	-	-
"Ready 3 UP" / "Ready 3 UP Plus" version		-	-	0	-	-	-
"eye-S" version		S	-	-	-	-	-
"eye-S 3 UP Plus" version		0	-	S****	-	-	-
"SCM Thundercut" Optimizer/Sequencer App		S	S	S	S	S	S
Expandable scoring blade		0	-	0	0	0	0
Surface reinforcement treatment for sliding table		0	0	0	0	0	0
Pushbuttons integrated in the sliding carriage		0	0	0	0	0	0
"Quick Lock" squaring fence		0	0	0	0	0	0
Squaring fence with LCD readouts for stops position		0	0	0	0	0	0
Fence for angular cutting on the sliding carriage		0	0	0	0	0	0
Fence for angular cutting with self-adjustment		0	0	0	0	0	0
Fence for angular cutting with electronic readouts and self-adjustment		0	0	0	0	0	0
Squaring frame with "Compex" device		0	0	0	0	0	0
Fence for complementary cutting		0	0	0	0	0	0
Fence for rip cutting on the sliding carriage		0	0	0	0	0	0
Fence for rip cutting on the sliding carriage with electronic readout		0	0	0	0	0	0
Inverter for electronic speed change from 2700 to 6000 rpm		S**	-	0	-	-	-
2-axis automatic adjustment of the scoring unit		S***	-	0	-	-	-
Electronic readout of parallel fence position		0	0	0	0	0	0
Presser on entire carriage length		0	0	0	0	0	0
Second extension with sliding rail support		0	0	0	0	0	0
Extension with roller conveyor on parallel fence side		0	0	0	0	0	0
"Pro-Lock" system for the main blade rapid locking		0	0	0	0	-	-
"LED indicating scoring unit in operation" device		0***	-	0	-	-	-
"DADO" machining		-	-	0	0	0	0
Machine configuration for advanced materials machining		0	-	0	0	0	0
Device for the blade micro-lubrication for the machining of plastic materials and light alloy		0	-	0	0	0	0
Overhead blades protection		S	S	S*	S*	0	0
Adjustable tablet holder positioned on the mobile control panel		0	-	0	-	-	-
Tablet holder on the sliding carriage		0	0	0	0	0	0
Blades-holder drawer integrated in the machine's frame		0	-	-	-	-	-
Laser device		0	0	0	0	0	-

* Standard for CE and USA-Canada versions; Option for NO CE version

** 3000 ÷ 5000 rpm speed

*** Scoring unit as option

**** Standard for "eye-S" version

circular saw with tiltable blade class px 350i



Blade tilting up to 46°.

		class px 350i
Max. saw blade diameter	mm	350
Max. saw blade projection from the table at 90°/45°	mm	105/72
Saw blade rotating speed	rpm	4000
Squaring stroke	mm	2600 ÷ 3800
Cutting width on rip fence	mm	1300
Three-phase motor power starting from	kW/Hz	5,5 (6,6) / 50 (60)
<i>Find the complete technical specification at page 25</i>		



class px 350i



Saw Unit
optimal finish



Rear Stop
immediate
positioning



Ready
simple and rapid
programmings



SCM
Thundercut
Optimizer/
Sequencer App

Circular saw with mobile carriage and tiltable blade up to 46° to operate in safety with working space reduced up to 50% compared to a traditional circular saw.

class px 350i operating groups and main devices



Simple and rapid
Programmed movement with the
"Ready" mobile control panel.



Sturdy telescopic squaring fence with the tilted metric
scale towards the operator and the 2 reversible stop:
panels squaring up to 2500x3000 mm (3200x3200 mm
as option). The fixed table of large dimensions guarantees
a stable panel support when machined.

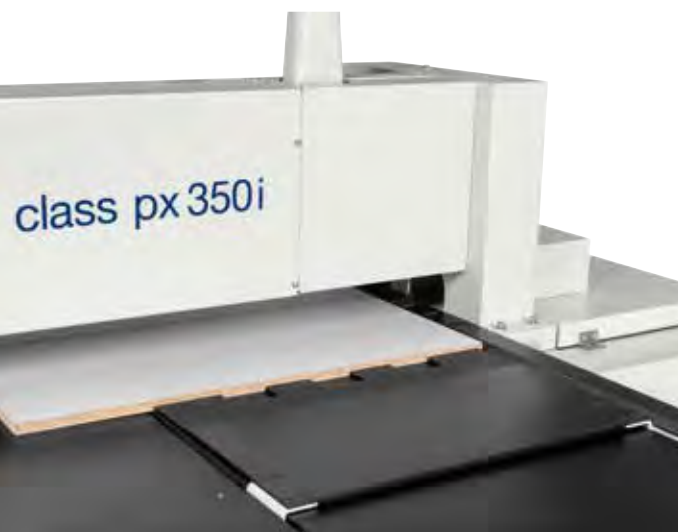

Immediate and precise positioning
thanks to the powered and
programmed rear stop.



Digital readouts
available for squaring fence, fence for angular
cutting and device for rip cuts.
(option)



class px 350i technical data

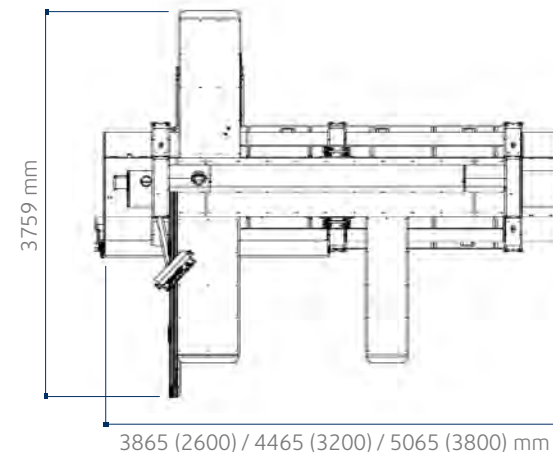

- ☐ Standard
- Option

Enlarged rear table
equipped with 2 powered stops
distributed on a length of 2000 mm,
it simplifies the cutting of long and
narrow panels.
(option)

Fence for angular cutting
It includes two
reversible stops.
(option)

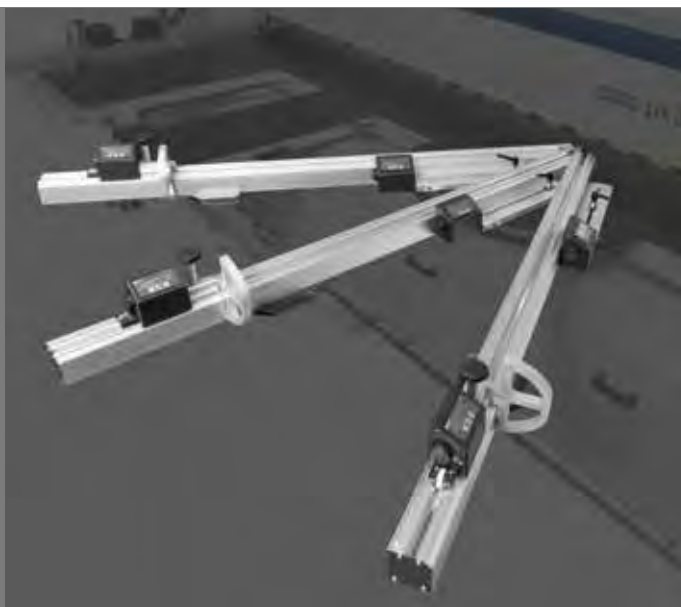

TECHNICAL DATA		class px 350i
Blades tilting		90° ÷ 46°
Max. saw blade diameter	mm	350
Max. saw blade projection from the table at 90°/45°	mm	105/72
Max. saw blade rotating speed	rpm	4000
Squaring stroke	mm	2600 ÷ 3800
Cutting width on rear fence	mm	1300
Max. telescopic fence extension	mm	2500
Max. feed speed of blade carriage	m/min	40
other technical features		
"SCM Thundercut" Optimizer/Sequencer App		S
Three-phase motor 5,5 kW (7,5 hp) 50 Hz - 6,6 kW (8 hp) 60 Hz		S
Three-phase motor 7 kW (9 hp) 50 Hz - 7 kW (9 hp) 60 Hz		O
Exhaus hoods diameter	mm	1 x 120 ; 2 x 100

automatic
multiblade
rip saw
class m 3



		class m 3
Max. saw blade diameter	mm	350
Saw blade sleeve diameter (blade bore)	mm	70
Max. width of blades pack	mm	300
Min. work-piece length	mm	390
Continuously adjustable feed belt speed	m/min	6 ÷ 48
Three-phase motor power starting from	kW/Hz	18,5 (22) / 50 (60)

Find the complete technical specification at page 29



Barriers
reliability and safety



Feed Belt
accuracy and efficiency



Saw Blade Shaft Sleeve
rapidity and effectiveness

Practical, accurate,
reliable and above all safe.

class m 3 operating groups and main devices



reliability and safety

Anti-kickback finger barriers

The SCM multiblade rip saw is equipped with 4 anti-kickback finger barriers: three top and one bottom and a chip deflector screen between the three top barriers.



accuracy and efficiency

Feed belt

The machine has an extremely substantial feed belt which is directly driven through its robust belt links. Unwanted movement of saw blade shaft sleeve is prevented by the aggressive surface of the feed belt and the 4 pressure rollers (2 in front and 2 behind the blades). These advanced features ensure maximum straightening and excellent cutting quality, minimizing the quantity of stock removal in successive machining.



practical and easy to use

Set-up

Setting up operations can be carried out rapidly: the adjustment of spindle, pressure rollers and feed speed is carried out by hand wheels according to graduated scale and direct reading. The infeed fence is fitted with selflocking lever which can be operated single-handed. The centralized control panel is equipped with ammeter to enable operator to obtain maximum output without motor stress.



rapidity and effectiveness

Saw blade shaft sleeve

It can be quickly fitted into spindle and easily locked with a special key. The conical coupling of the saw blade shaft sleeve with the base of spindle ensures longer blade life and higher output.

Laser

Laser beam cutting line reference.

Some typical uses:

- extraction of irregular planks, without using fences
- selection of clear parts of planks with knots and fissures (option)



class m 3 technical data

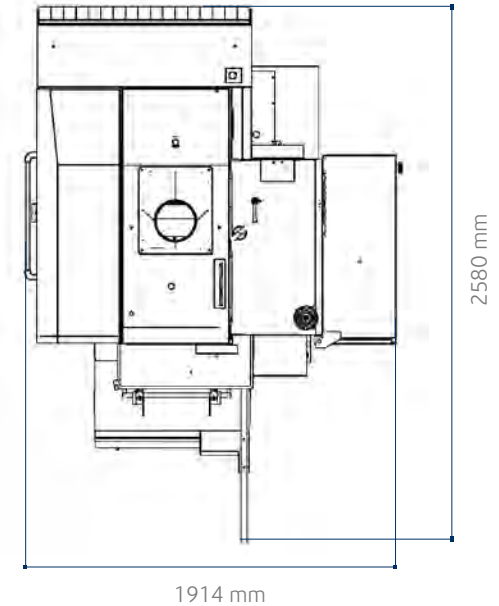

- ☐ Standard
- Option

TECHNICAL DATA		class m 3
Max. saw blade diameter	mm	350
Min. saw blade diameter	mm	200
Saw blade sleeve diameter (blade bore)	mm	70
Keys dimensions on the saw blade sleeve	mm	20 x 5
Blader rotation speed	rpm	4200
Max. width of blades pack	mm	300
Feed belt width	mm	300
Min. work-piece length	mm	390
Worktable dimensions	mm	1530 x 950
Worktable height from the floor	mm	750
Distance between base and first right blade	mm	200
Continuously adjustable feed belt speed	m/min	6 ÷ 48
other technical features		
Three-phase motor 18,5 kW (25 hp) 50 Hz - 22 kW (30 hp) 60 Hz		S
Three-phase motor 25 kW (30 hp) 50 Hz - 30 kW (42 hp) 60 Hz		O
Three-phase motor 37 kW (50 hp) 50 Hz - 44 kW (60 hp) 60 Hz		O
Feed belt motor power at 50 Hz (at 60 Hz)	hp	1,5 ÷ 2 (1,8 ÷ 2,4)
Exhaus hoods diameter:		
- at the blades	mm	200
- at the feed belt	mm	120

surface planers
 class f 520
 class f 410



		class f 520	class f 410	class s 630	class s 520
Working width	mm	520	410	630	520
Cutterblock diameter/standard knives	mm/n.	120/4	120/4	120/4	120/4
Total worktable length	mm	2750	2610	-	-
Max. stock removal	mm	8	8	8	8
Min. ÷ max. working height on thicknesser		-	-	3,5 ÷ 300	3,5 ÷ 300
Three-phase motors power starting from	kW/Hz	5 (6) / 50 (60)	5 (6) / 50 (60)	7 (8) / 50 (60)	7 (8) / 50 (60)

Find the complete technical specification at page 36

thicknessing planers

class s 630
class s 520



Surface Fence
high rigidity

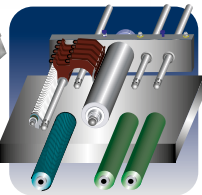

Interchangeable Rollers
for every requirement



SCM Cutterblock
simple and rapid

Easy to use and precise, stylish with practical design, a wider range of applications.

planers operating groups

high rigidity Surface fence

High rigid fence with a smooth movement thanks to the **central locking on round bar**. The graduated scale facilitates the operator in positioning the guide to the required tilting.

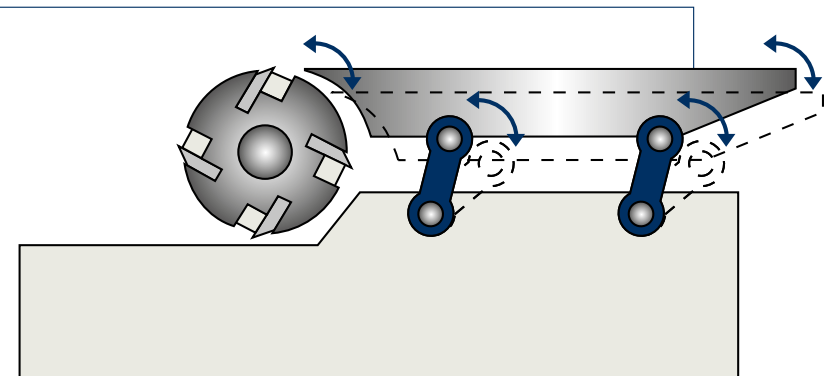
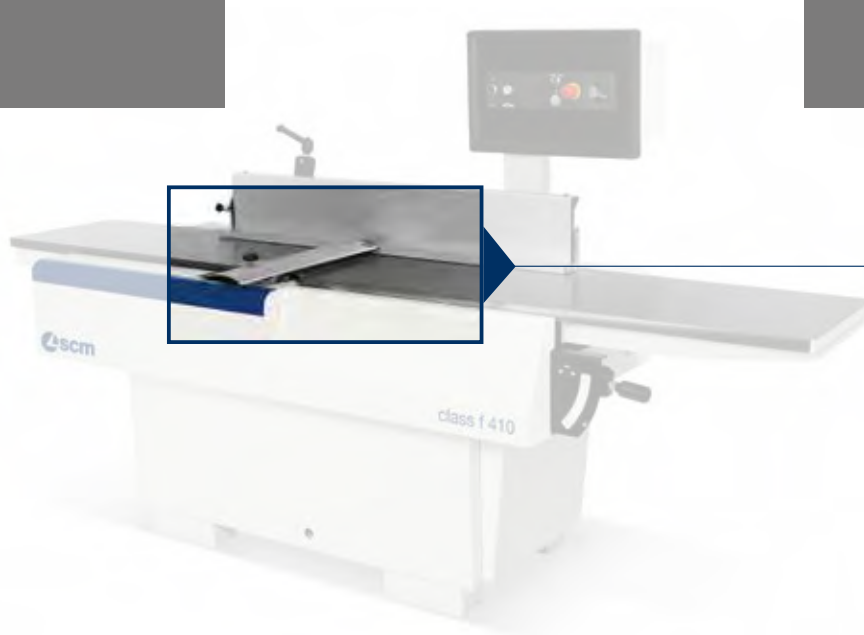
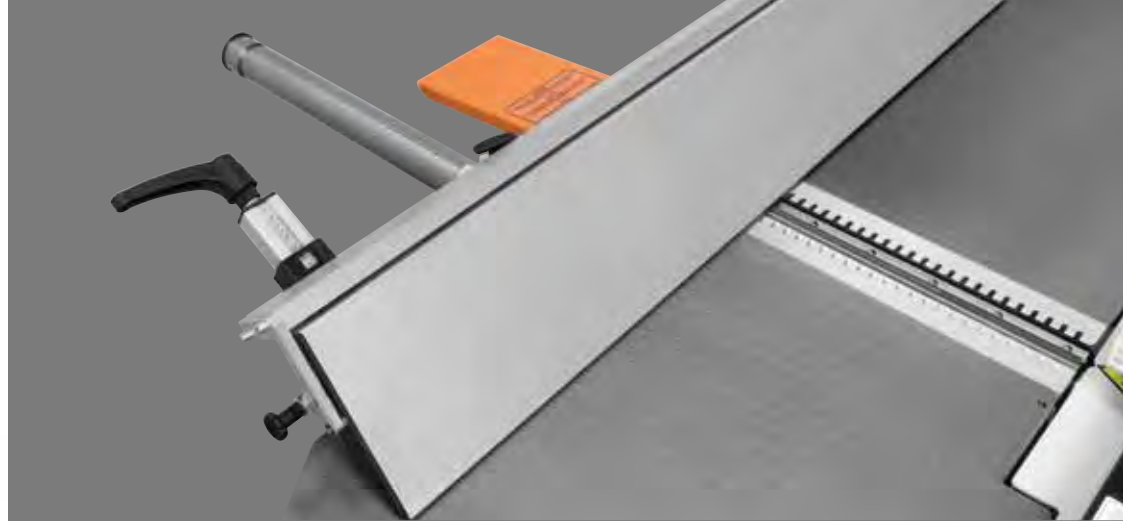

constant precision over time

Feeding on connecting rods

Very accurate machining with the movement of the infeed table by means of a parallelogram **kinetic mechanism which always gives the same distance between the cutterblock and the table**. The system operating directly on the connecting rods avoids any exertion to the table assuring constant planarity over time.

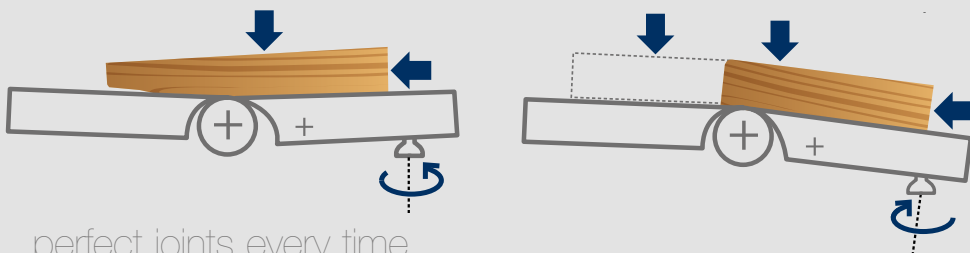

perfect joints every time

Concave-convex function

The available settings allow **perfect bonding** of the components giving excellent coupling and eliminating any joint line.



perfect finish

Feeding rollers on connecting rods

The stopping of the work-piece and the presence of notches on its surface are eliminated due to the movement system on all three rollers, that allows their vertical displacement by rotation and the **best linear feeding**. Perfect surfaces and high feeding performance with the standard rubber rollers.

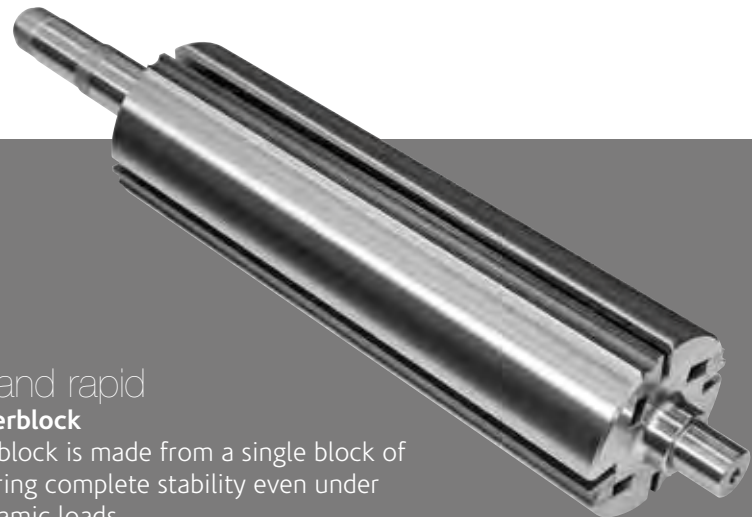

simple and rapid

SCM cutterblock

The cutterblock is made from a single block of steel ensuring complete stability even under heavy dynamic loads.

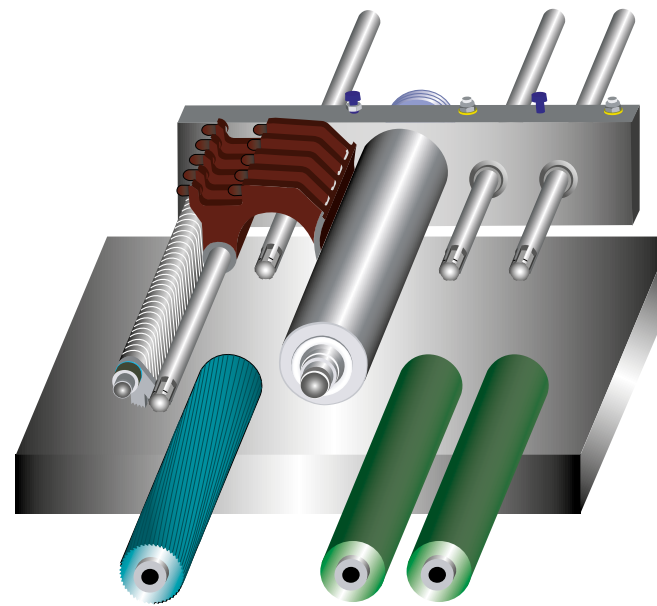

solutions for every requirement

Interchangeable rollers

Perfect finish obtained by quick and easy changeover of the rollers that allows the operator to configure the machine drive function in case of special requirements, such as a minimum removal of fine wood and/or batches where multiple pieces of different thicknesses are processed.

Powered worktable lifting with micrometric adjustment and digital readout.

Feed speed controlled by inverter from control panel and dedicated warning light to indicate to higher speed.

The 4 screws with a large diameter combined with the 2 side linear guides ensure worktable stability. The integrated protections guarantee high precision and reliability over time.

Pneumatic load adjustment on the rollers for the best finish and effectiveness of the feeding of any material and in any working condition. *(option)*



planers main optional devices

"Xylent" spiralknife cutterblock
The 3 spiralknives give an exceptional finish. **Reduced noise** during machining provides a more comfortable working environment. It also improves the dust extraction due to the **production of very small chips**. Each cutter has 4 tips which can be rotated into the cutting position when worn. Therefore, increasing the production life of the cutter block before knives require replacement.



Maintenance case for "Xylent" spiralknife cutterblock

It includes:

- 1 cleaning/degreasing liquid bottle for the resins cleaning
- 1 set dynamometric key - 2 bit Torx
- 10 inserts - 5 screws - 1 brass bristle brush to clean the spindle with mounted in inserts - 1 steel bristle brush to clean the inserts housings



Additional overturning fence

Integrated in the surface fence, it ensures perfect operator safety when machining small dimensioned work-pieces.



"Tersa" monoblock cutterblock

The cutterblock is made from a single block of steel ensuring complete stability even under heavy dynamic loads. Automatic knives clamping by means of the centrifugal force ensures safe and precise machining. The system, without fixing screws, makes knives substitution extremely fast.

"Smart Lifter" integrated protection
The protection system, **developed by SCM**, is perfectly integrated into the machine base for **maximum protection** while excluding any hindrance or obstruction in the work. The protection with automatic vertical, horizontal and tilted movements **provides complete coverage of the tool** before, during and after machining.





Thickening table extension to be used in infeed or outfeed

It can be installed on the worktable end side.

Outfeed rollers in sandblasted steel

For a perfect post-processing finish.



Special rollers

The sectioned steel roller (a) and the dual-density rubber roller (b) allow the simultaneous processing of different thicknesses giving great results even with minimum removal. With the dual-density rubber roller, the edges are not damaged even when the work-pieces are not perfectly aligned. Suitable also for upgraded woods and/or thin thicknesses.



a



Outfeed extension for the thickening table

A single operator can easily move very long panels or introduce a second one without going to the outside to stop the first one.

Thickening table with idle rollers

It enables the feeding of moist and/or resinous wood. Particularly suitable for heavy duty woodworking operations and with rough work-pieces.

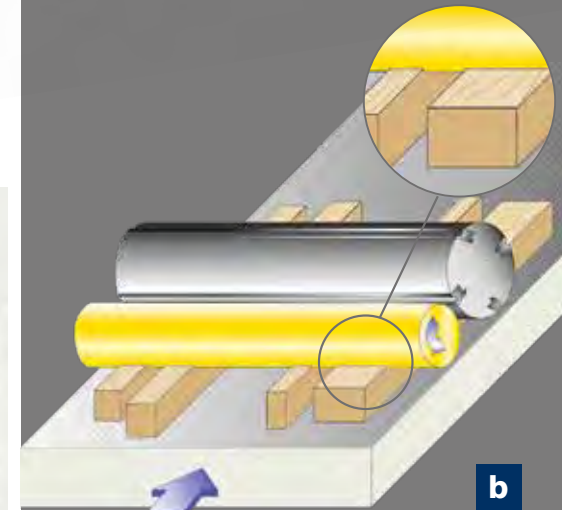

b



Advanced materials machining

PVC and other plastic materials. Nylon, polycarbonate and other synthetic materials.



planers technical data

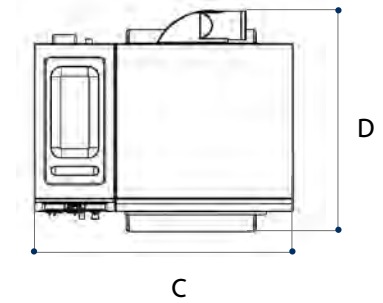
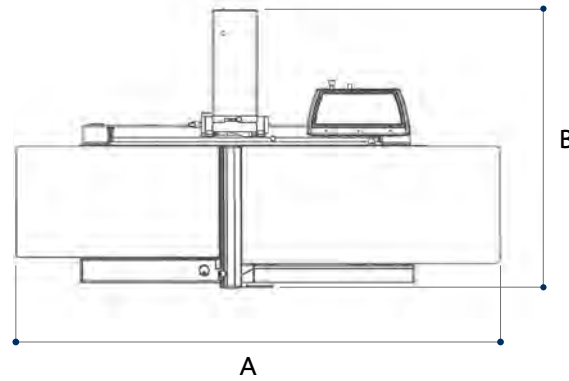

S Standard
O Option

TECHNICAL DATA		class f 520	class f 410	class s 630	class s 520
Working width	mm	520	410	630	520
Cutterblock diameter/standard knives	mm/n.	120/4	120/4	120/4	120/4
Standard knives dimensions	mm	35 x 3 x 520	35 x 3 x 410	35 x 3 x 640	35 x 3 x 520
Max. stock removal	mm	8	8	8	8
Total worktable length	mm	2750	2610	-	-
Thickening table dimensions	mm	-	-	640 x 1000	530 x 900
Feed speed on thickener	m/min	-	-	4 ÷ 20	4 ÷ 20
Min. ÷ max. working height on thickener	mm	-	-	3,5 ÷ 300	3,5 ÷ 300
other technical features					
Three-phase motors 5 kW (6,6 hp) 50 Hz - 6 kW (8 hp) 60 Hz		S	S	-	-
Three-phase motors 7 kW (9,5 hp) 50 Hz - 8 kW (11 hp) 60 Hz		-	-	S	S
Three-phase motor 9 kW (12 hp) 50 Hz - 11 kW (15 hp) 60 Hz		-	-	O	O
Exhaust hood diameter	mm	120	120	150	150

OVERALL DIMENSIONS		class f 520	class f 410	class s 630	class s 520
A	mm	2750	2610	-	-
B	mm	1416	1155	-	-
C	mm	-	-	1280	1130
D	mm	-	-	1095	1017

MAIN OPTIONAL DEVICES	class f 520	class f 410	class s 630	class s 520
"Tersa" monoblock cutterblock	0	0	0	0
"Xylent" spiralknife cutterblock with 3 spiralknives	0	0	0	0
Maintenance case for "Xylent" spiralknife cutterblock	0	0	0	0
Additional overturning fence for the processing of thin work-pieces	0	0	-	-
"Smart Lifter" integrated protection	0	0	-	-
Worktable with 2 idle rollers	-	-	0	0
First front roller with rubber coating in place of the grooved steel one	-	-	0	0
First front sectioned steel roller in place of the grooved one	-	-	0	0
First front dual-density rubber roller in place of the grooved steel one	-	-	0	0
Outfeed steel rollers in place of the rubber-coated ones	-	-	0	0
Pneumatic pressure adjustment on the feeding rollers	-	-	0	0
Thicknessing table extension to be used in infeed or outfeed	-	-	0	0
Outfeed extension for the thicknessing table	-	-	0	0
Machine configuration for advanced materials machining	-	-	0	-

electronically and
programmable
spindle moulders
class ti 145ep
class ti 120e
class tf 130e



		class ti 145ep	class ti 120e	class tf 130e
Spindle height CE Ø 30-35 (40-50)	mm	140 (160)	140 (180)	140 (180)
Max. diameter of the profiling tool	mm	250	250	250
Max. tool diameter retractable under worktable at 90°	mm	300	320	300
Max. diameter of tenoning tool CE Ø 30-35 (40-50)	mm	300 (300)	300 (350)	300 (300)
Three-phase motors power starting from	kW/Hz	7 (8) / 50 (60)	5 (6) / 50 (60)	7 (8) / 50 (60)

Find the complete technical specification at page 48



Spindle Moulder Unit
sturdiness and versatility



Spindle Moulder Fence
set-up rapidity



Electronic Control
operating advantage



Machine Versions
specialisation and professionalism

More quality, more performance,
more reliability.

manual
 spindle moulders
 class tf 130
 class tf 130ps
 class ti 120



		class tf 130	class tf 130ps	class ti 120
Spindle height CE Ø 30-35 (40-50)	mm	140 (180)	140 (180)	140 (180)
Max. diameter of the profiling tool	mm	250	250	250
Max. tool diameter retractable under worktable at 90°	mm	300	320	320
Max. diameter of tenoning tool CE Ø 30-35 (40-50)	mm	300 (350)	300 (350)	300 (350)
Three-phase motors power starting from	kW/Hz	7 (8) / 50 (60)	7 (8) / 50 (60)	5 (6) / 50 (60)

Find the complete technical specification at page 48



Spindle Moulder Unit
sturdiness and versatility



Spindle Moulder Fence
set-up rapidity



Machine Versions
specialisation and professionalism

Precision and reliability in unbeatable time.

spindle moulders operating groups

easy to use

Adjustable spindle moulder fence

A handle provides the setting-up of the infeed table, which effects the removal and it is verified by an index on a metric scale.



sturdiness and versatility

Spindle moulder unit

Maximum stability and rigidity in all working conditions, thanks to a **large spindle moulder column made entirely of cast iron.**

The spindle is surrounded by a cast iron "cup" to protect the internal mechanical components from shavings and sawdust. The 5 standard speed are ideal for any type of machining, from profiling to moulding and tenoning, with the possibility to fit large diameter tools.



the best support for the worktable

"Fast" sectional table

Provides support for the work-piece being machined close to the tool, allowing the adjustment with mounted tools and the very best quality finish when machining narrow pieces. The extremes in machinable material eliminate the disadvantages of a possible collision with the tool.

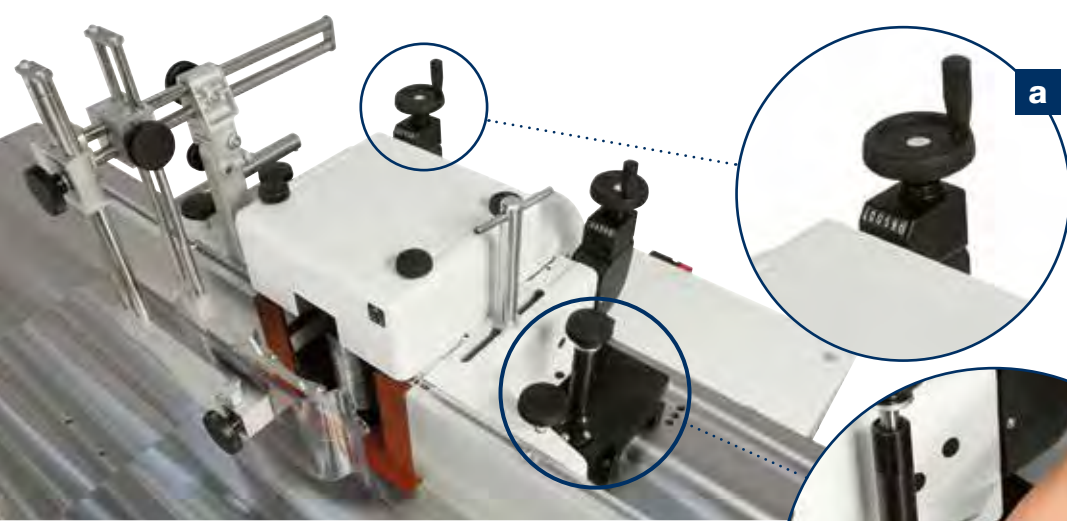

maximum set-up speed and ease-of-use
Spindle moulder fence with mechanical programming
 No more test runs due to digital readouts (a) that ensure accuracy to a tenth of a millimetre in positioning the two worktables. The side handles (b) make it easy to remove and reposition the fence from the worktable.

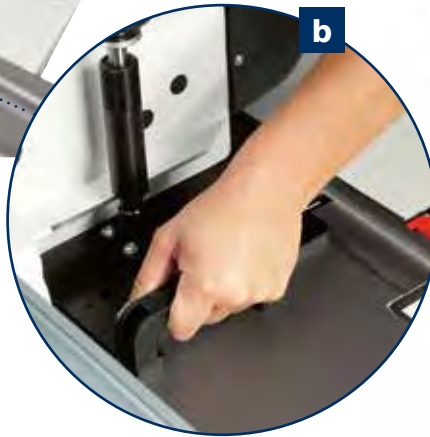

automatic and removable
"Flex One" spindle moulder fence

Automatic adjustment of the entire fence according to the tool diameter. User-friendly worktable exclusion system with precise re-positioning.



machining with tools on the spindle head carried out with the "Flex" fence

The spindle moulder fence can be located behind the tool allowing the performance of "head" routing using small diameter tools, typical of a router or portable electric tools; all this in compliance with CE safety regulations.

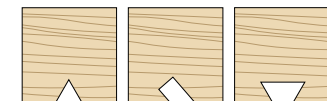

engraving,
 grooving,
 mortising

immediately in the correct position
"Flex" system
 A single, simple movement to retract and re-position instantly and accurately the position of the fence on the worktable with such precision that no other control is necessary.



spindle moulders machine versions



class tf 130ps
with front sliding carriage
Designed to manage tenoning operations very easily.



"LL" versions with worktable side extensions
Ideal when machining very long work-pieces due to worktable extensions. The mobile front bar makes it easy to move large dimensioned work-pieces on the worktable, particularly for edge profiling.



Carriage on worktable for small tenoning operations
Ideal for tenoning of small work-pieces for the versions without sliding carriage. Mitre cuts with angles of $\pm 60^\circ$ on the worktable are possible. Easy fitting and removal due to the fixing system on the worktable.



"TL PRO-10" versions

The manual feed carriage is a cast iron structure running on linear slideways with recirculating ball screws, guaranteeing maximum machining precision and stability.



The "PRO-10" tenoning table can be retracted easily and within a few seconds to leave the machine ready for profiling (a) or moulding (b) operations.



For a total safety and a higher flexibility, the machine is supplied, as standard feature, with a **special protection hood** for moulding operations.



"TL" versions

Top machining precision and stability due to the manual feed carriage with castiron structure mounted on axial bearings running on slideways made from hardened and ground bar.

spindle moulders electronic controls

Technical specification at page 49

the pleasure of controlling all machine functions from the control panel

"eye-S" console

The new control panel, with its attractive design, allows easy and intuitive machine programming, combining the 15" colour touch-screen display and the **Maestro** active user interface. Main functions:

- Connectivity among machines belonging to the same company network and **4.0 Industry** preset
- Sharing of work programs and tools database
- Activity monitoring and reporting on the use of the machine
- Self-diagnosis, tele-service and link to troubleshooting



"Ready"

The programming of the work becomes simple and effective with the electronic control with a 4" LCD colour screen. Working mode: manual, semi-automatic and automatic with a memory capacity of up to 99 programs.



Tool-holder shaft lifting



Adjustment of the entire profiling fence



Tool-holder shaft tilting



Tool-holder shaft speed readout

For the most recurring machining jobs it is possible to set the dimensions of the required profile and select the tool to be used. The controls will create the dedicated program to carry out the require machining operations.

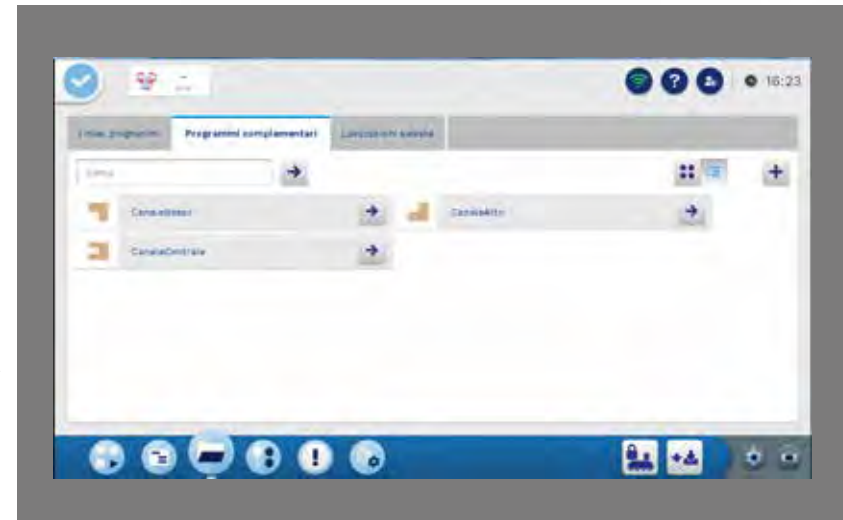

Powered operating unit movement with digital readouts.

Maximum precision and ease-of-use.

The "eye-S" control can manage the inverter for the adjustment of spindle rotation speed. (option)

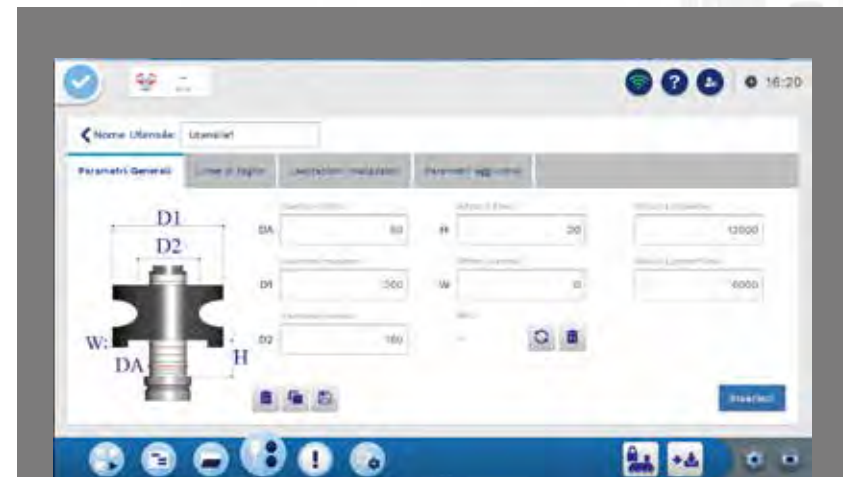

spindle moulders main optional devices

Feeder support device

High usable flexibility and no use of worktable space, due to the cross device on the column support of the overhead control panel. The positions are made extremely simple using handwheels with digital readout.



"T-Set" rapid tool locking

A simple compressed air gun allows the tools locking and unlocking when the interchangeable spindle is present.



Advanced materials machining

PVC and other plastic materials. Nylon, polycarbonate and other synthetic materials.

spindle moulders technical data

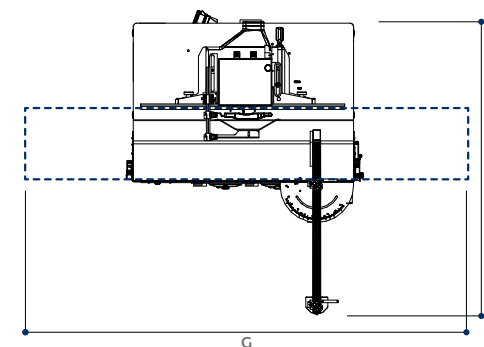
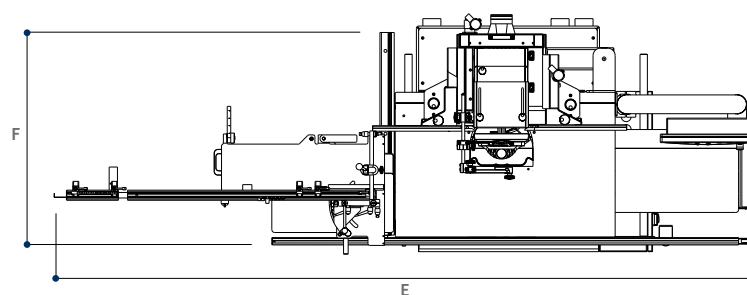
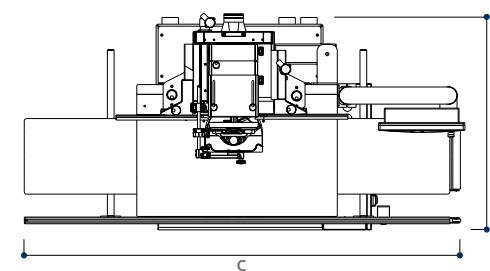
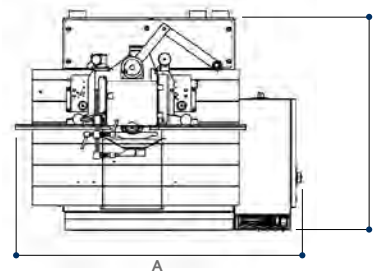

S Standard
O Option

TECHNICAL DATA		class ti 145ep	class ti 120e	class tf 130e	class tf 130	class tf 130ps	class ti 120
Worktable dimensions	mm	1200 x 780	1200 x 810	1200 x 730	1200 x 730	1080 x 760	1200 x 810
Spindle tilting		-45,5° ÷ +45,5°	-45° ÷ +45°	-	-	-	-45° ÷ +45°
Spindle height CE Ø 30-35 (40-50)	mm	140 (160)	140 (180)	140 (180)	140 (180)	140 (180)	140 (180)
Spindle speed (at 50 Hz)	rpm	3000/4500/6000/ 7000/10.000	3000/4500/6000/ 7000/10.000	3000/4500/6000/ 7000/10.000	3000/4500/6000/ 7000/10.000	3000/4500/6000/ 7000/10.000	3000/4500/6000/ 7000/10.000
Max. diameter of the profiling tool	mm	250	250	250	250	250	250
Max. tool diameter retractable under worktable at 90°	mm	300	320	300	300	320	320
Max. diameter of tenoning tool CE Ø 30-35 (40-50)	mm	300 (300)	300 (350)	300 (300)	300 (350)	300 (350)	300 (350)
other technical features							
Three-phase motors 5 kW (6,6 hp) 50 Hz - 6 kW (8 hp) 60 Hz		-	S	-	-	-	S
Three-phase motors 7 kW (9,5 hp) 50 Hz - 8 kW (11 hp) 60 Hz		S	O	S	S	S	O
Three-phase motors 9 kW (12 hp) 50 Hz - 11 kW (15 hp) 60 Hz		O	O	O	O	-	O
Exhaust hood diameter:							
- at the base	mm	100	2 x 80	120	120	120	2 x 80
- on the spindle moulder fence	mm	120	120	120	120	120	120

OVERALL DIMENSIONS		class ti 145ep	class ti 120e	class tf 130e	class tf 130	class tf 130ps	class ti 120
A	mm	1655	1194	1324	1324	-	1194
B	mm	1265	1280	1010	1010	-	1280
C	mm	2600	2600	2600	2600	-	2600
D min.	mm	1265	1300	1340	1340	-	1300
D max.	mm	1575	1710	1650	1650	-	1710
E	mm	3780	3520	3551	3551	-	3197
F min.	mm	1375	1300	1340	1340	-	1300
F max.	mm	1685	1710	1650	1650	-	1710
G	mm	-	-	-	-	2080	-
H	mm	-	-	-	-	2740	-

MAIN OPTIONAL DEVICES	class ti 145ep	class ti 120e	class tf 130e	class tf 130	class tf 130ps	class ti 120
"Ready" version	S	-	-	-	-	-
"eye-S" version	S*	-	-	-	-	-
<i>class tf 130ps</i> with front sliding carriage	-	-	-	-	S	-
Mobile control panel	O	-	O	O	-	-
Powered operating unit movement with digital readouts	-	S	S	-	-	-
"Flex" spindle moulder fence	O	O	O	O	O	-
"Flex One" spindle moulder fence	O	-	-	-	-	-
Inverter for the rotation speed adjustment from 900 to 10.000 rpm	O	-	-	-	-	-
Feeder support device with manual vertical and horizontal movements	O	-	O	O	-	-
Spindle moulder fence with mechanical programming	S	S	S	O	O	O
Aluminium tabled instead of the wooden ones for profiling fence	O	O	O	O	O	O
Interchangeable spindle	S	O	O	O	O	O
Spindle for router bits	O	O	O	O	O	O
"T-Set" rapid tool locking	O	-	O	O	O	-
"Fast" sectional table with manual adjustment	S	-	S	O	-	-
"LL" version with 2 cast-iron profiling extensions	O	O	O	O	-	O
"TL" version for tenoning and profiling	O	O	O	O	-	O
"TL PRO-10" version for tenoning and profiling	O	-	O	O	-	-
Tenoning table and tenoning hood	-	-	-	-	S	-
Carriage on the fixed table for small tenoning operations	O	O	O	O	-	O
Machine configuration for advanced materials machining	O	-	O	O	O	-

* Standard for "eye-S" version

PROMPT AND EXPERT TECHNICAL SUPPORT THROUGH A NETWORK OF 1000 TECHNICIANS AND AN INVENTORY OF 36,000 SPARE PARTS.

HIGHLY SPECIALISED TECHNICIANS, EFFICIENT
MANAGEMENT AND 6 SPARE PARTS BRANCHES
AROUND THE WORLD GUARANTEE A CLOSE,
SAFE AND EFFECTIVE TECHNICAL SUPPORT.

SERVICE

SCM provides a service that goes beyond the purchase, to guarantee the long term performance of your technological production system and peace of mind for your business.

A COMPLETE RANGE OF AFTER-SALES SERVICES

- installation and start-up of machines, cells, lines and systems
- tailored training programs
- telephone support to reduce times and costs when machines are not working
- preventive maintenance programs to guarantee long term performance
- complete renovation of machines and plants to renew the added value of the investments
- custom upgrading to update machines and plants and meet new production requirements



SPARE PARTS

SCM Group can count on 140 spare parts professionals worldwide to meet any request with real time shipments.



36,000 SPARE PARTS

Our spare parts inventory, with a value of 12 million euros, covers every single machine



SPARE PARTS GUARANTEED

We guarantee also hard to find parts, with 3,5 million euros invested in "critical" spare parts.



IMMEDIATE AVAILABILITY

Over 90% of orders received are carried out the same day thanks to the huge inventory available.



6 BRANCHES AROUND THE WORLD

The spare parts service can count on worldwide support (Rimini, Singapore, Shenzhen, Moscow, Atlanta, São Bento do Sul)



500 SHIPMENTS A DAY



THE STRONGEST WOOD TECHNOLOGIES ARE IN OUR DNA

SCM. A HERITAGE OF SKILLS IN A UNIQUE BRAND

Over 65 years of success gives SCM the centre stage in woodworking technology. This heritage results from bringing together the best know-how in machining and systems for wood-based manufacturing. SCM is present all over the world, brought to you by the widest distribution network in the industry.

65+ years history

3 main production sites in Italy

300.000 square metres of production space

20.000 machines manufactured per year

90% export

20 foreign branches

400 agents and dealers

500 support technicians

500 registered patents



In SCM's DNA also strength and solidity of a great Group. The SCM Group is a world leader, manufacturing industrial equipment and components for machining the widest range of materials.

SCM GROUP, A HIGHLY SKILLED TEAM EXPERT IN INDUSTRIAL MACHINES AND COMPONENTS

INDUSTRIAL MACHINERY

Stand-alone machines, integrated systems and services dedicated to processing a wide range of materials.



WOODWORKING TECHNOLOGIES



TECHNOLOGIES FOR PROCESSING COMPOSITE MATERIALS, ALUMINIUM, PLASTIC, GLASS, STONE, METAL

INDUSTRIAL COMPONENTS

Technological components for the Group's machines and systems, for those of third-parties and the machinery industry.



SPINDLES AND TECHNOLOGICAL COMPONENTS



ELECTRIC PANELS



METALWORK



CAST IRON



SCM GROUP SPA

via Casale 450 - 47826 Villa Verucchio, Rimini - Italy
tel. +39 0541 674111 - fax +39 0541 674274
scm@scmgroup.com
www.scmwood.com



00L0590133G